

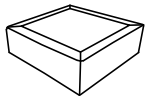





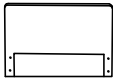

NO/ NON.	PARTS LIST/ LISTE DES PIÈCES	QTY/ QTÉ	DESCRIPTION	NO/ NON.	PARTS LIST/ LISTE DES PIÈCES	QTY/ QTÉ	DESCRIPTION
A		1	Seat Frame/ Cadre de siège	F		4	Allen Bolt/ Boulon Allen ØM8*50
B		1	Back Rest/ Dossier	G		4	Lock Washer/ Rondelle de blocage M8
C		1	Seat Cushion/ Coussin de siège	H		4	Flat Washer/ Rondelle plate M8*Ø22*1.5mm
D		1	Back Cushion/ Coussin de dossier	I		1	Allen Key/ Clé Allen M5*100*50mm
E		4	Wooden Leg/ Pied en bois	K			

STEP 1/ ÉTAPE 1:

Take out Back Rest(B), Seat Cushion(C), Back Cushion(D), Wooden Leg(E), Allen Bolt(F), Lock Washer(G), Flat Washer(H), Allen Key(I).

Retirez le dossier (B), le coussin d'assise (C), le coussin de dossier (D), le pied en bois (E), le boulon Allen (F), la rondelle frein (G), la rondelle plate (H) et la clé Allen (I).

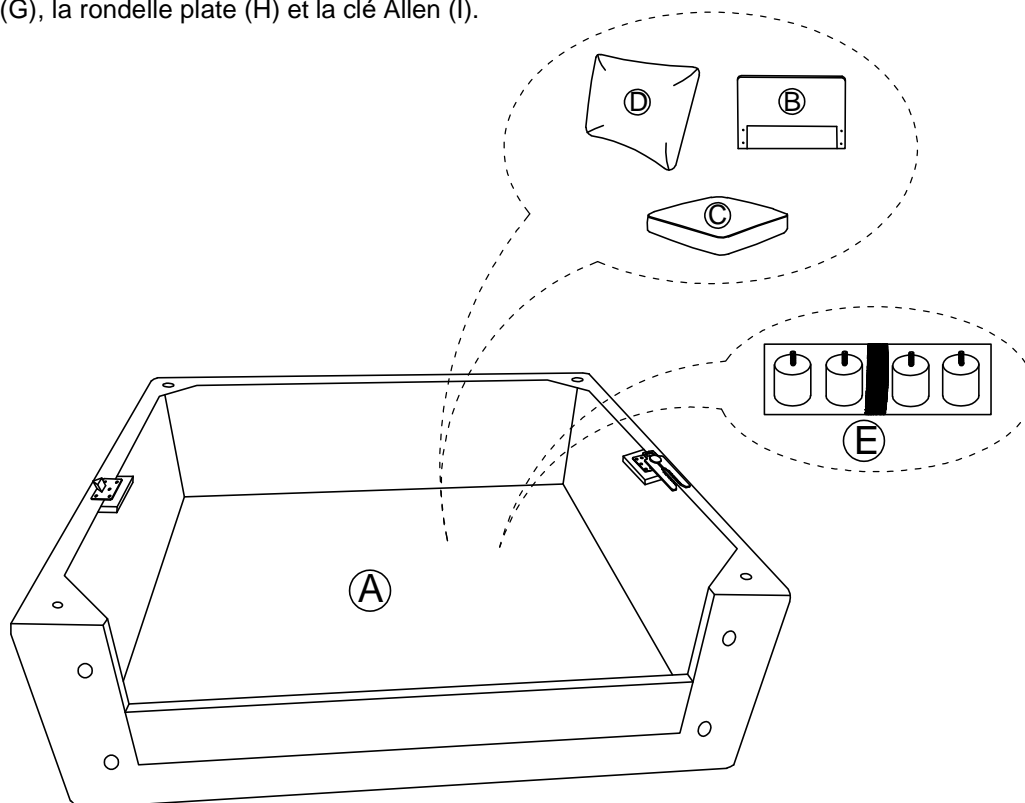

STEP 2/ ÉTAPE 2:

Align Wooden Leg (E) onto the bottom of the Seat Frame(A), rotate to tighten it.
 Alignez le pied en bois (E) sur le bas du cadre du siège (A), tournez pour le serrer.

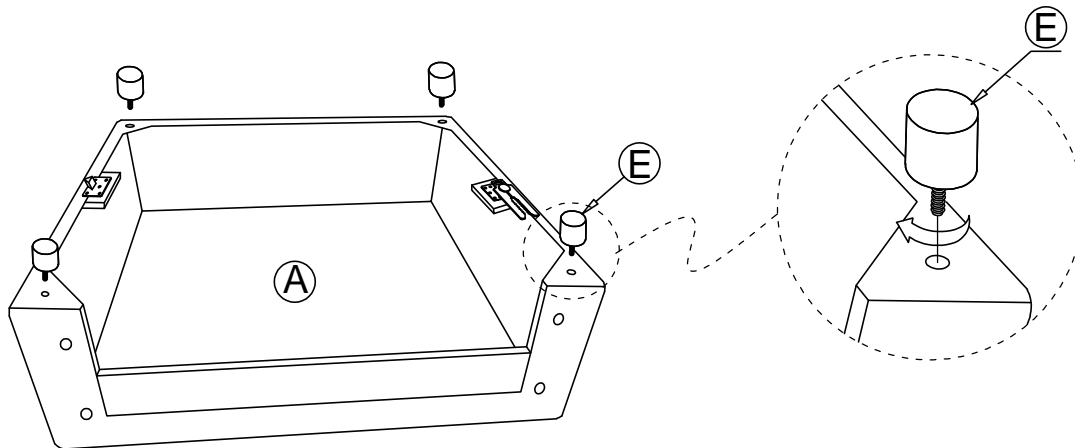

STEP 3/ ÉTAPE 3:

Place seat cushion on the seat frame.
 Match holes of Back Rest(B) and Seat Frame(A) correctly. Serew Allen Bolt(F) Lock Washer(G), and Flat Washer(H) with Allen Key(I).

Placez le coussin d'assise sur le cadre du siège.
 Alignez correctement les trous du dossier (B) et du cadre du siège (A). Vissez la vis Allen (F), la rondelle frein (G) et la rondelle plate (H) à l'aide de la clé Allen (I).

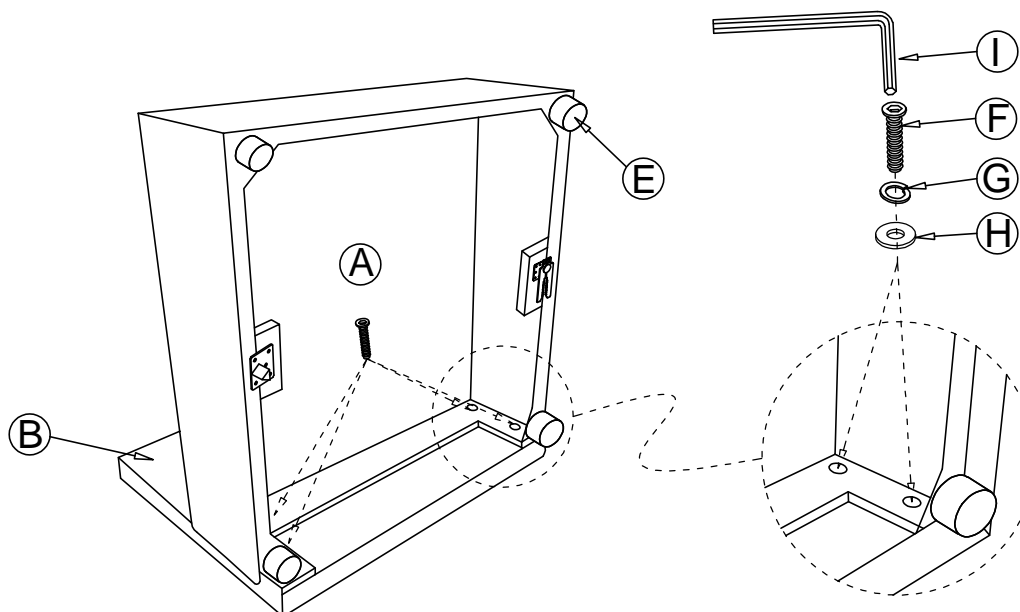

STEP 4/ ÉTAPE 4:

Put Seat Cushion(C) on the Seat Frame(A).
Placez le coussin de siège (C) sur le cadre de siège (A).

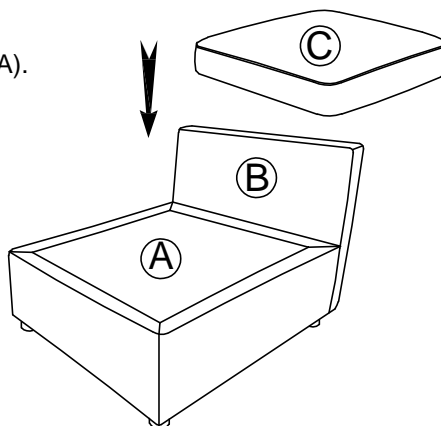

STEP 5/ ÉTAPE 5:

Put Back Cushion(D) on Seat Cushion(C).
Placez le coussin de dossier (D) sur le coussin de siège (C).

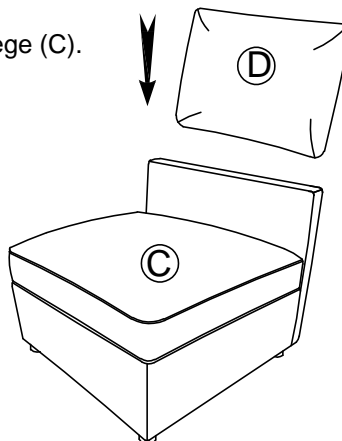

STEP 6/ ÉTAPE 6

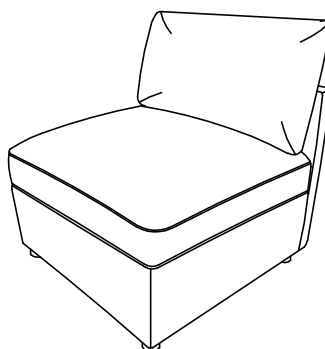

(Completed/ Complété):



CARE INSTRUCTIONS FOR FABRIC FURNITURE

To maintain the original appearance of your fabric furniture, please follow the simple care procedures below:

- * Avoid exposing furniture directly to sunlight or heating and air conditioning outlets. Exposure to sunlight or heating and air conditioning outlets will fade/damage fabric.
- * Wipe gently with a damp soft cloth to remove dust, dirt and any grime build up.

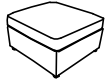
NO/ NON.	PARTS LIST/ LISTE DES PIÈCES	QTY/ QTÉ	DESCRIPTION
A		2	CR-Corner Seat/ Siège d'angle CR
B		2	AC-Armless Chair/ Chaise sans accoudoirs AC
C		1	4-Ottoman

STEP 7/ ÉTAPE 7:

Sectional connection by placing (B) into piece (A) Continue sectional connection with piece (C) and (B) the same method.

Assemblage par sections en plaçant (B) dans la pièce (A) Continuer l'assemblage par sections avec la pièce (C) et (B) de la même manière.

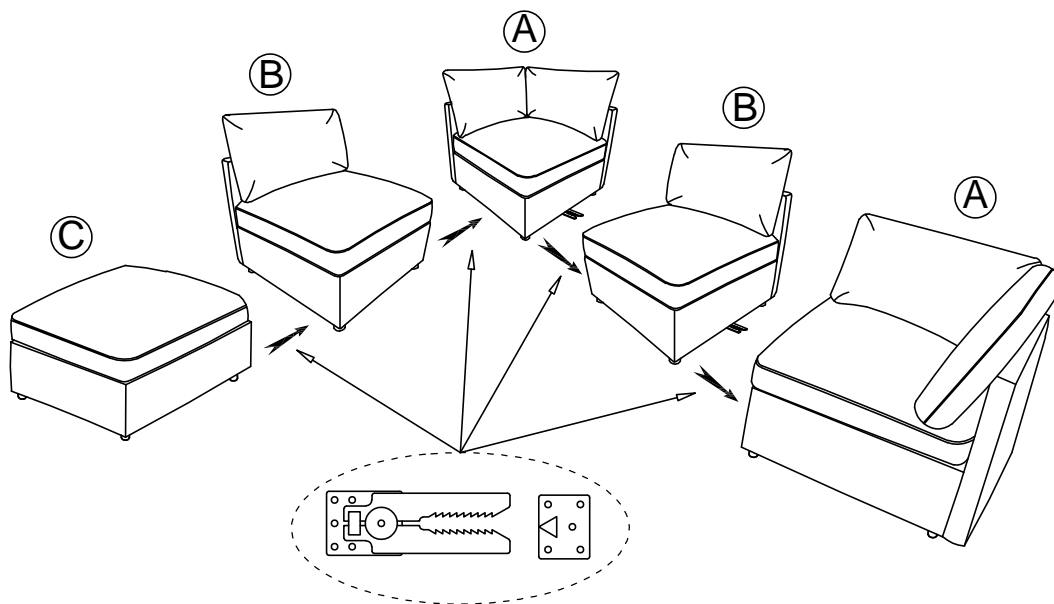

STEP 8/ ÉTAPE 8

(Completed/ Complété):

