

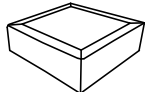







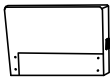

NO/ NON.	PARTS LIST/ LISTE DES PIÈCES	QTY/ QTÉ	DESCRIPTION	NO/ NON.	PARTS LIST/ LISTE DES PIÈCES	QTY/ QTÉ	DESCRIPTION
A		1	Seat Frame/ Cadre de siège	G		4	Wooden Leg/ Pied en bois
B		1	Left Back Rest/ Dossier gauche	H		8	Allen Bolt/ Boulon Allen ØM8*50
C		1	Right Back Rest/ Dossier droit	I		8	Lock Washer/ Rondelle de blocage M8
D		1	Seat Cushion/ Coussin de siège	K		8	Flat Washer/ Rondelle plate M8*Ø22*1.5mm
E		1	Left Back Cushion/ Coussin arrière gauche	L		1	Allen Key/ Clé Allen M5*100*50mm
F		1	Right Back Cushion/ Coussin de dossier droit				

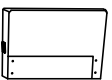
## STEP 1/ ÉTAPE 1:

Take out Left Back Rest(B), Right Back Rest(C), Seat Cushion(D), Left Back Cushion(E), Right Back Cushion(F), Wooden Leg(G), Allen Bolt(H), Lock Washer(I), Flat Washer(K), Allen Key(L).

Retirez le dossier gauche (B), le dossier droit (C), le coussin d'assise (D), le coussin de dossier gauche (E), le coussin de dossier droit (F), le pied en bois (G), le boulon Allen (H), la rondelle frein (I), la rondelle plate (K) et la clé Allen (L).

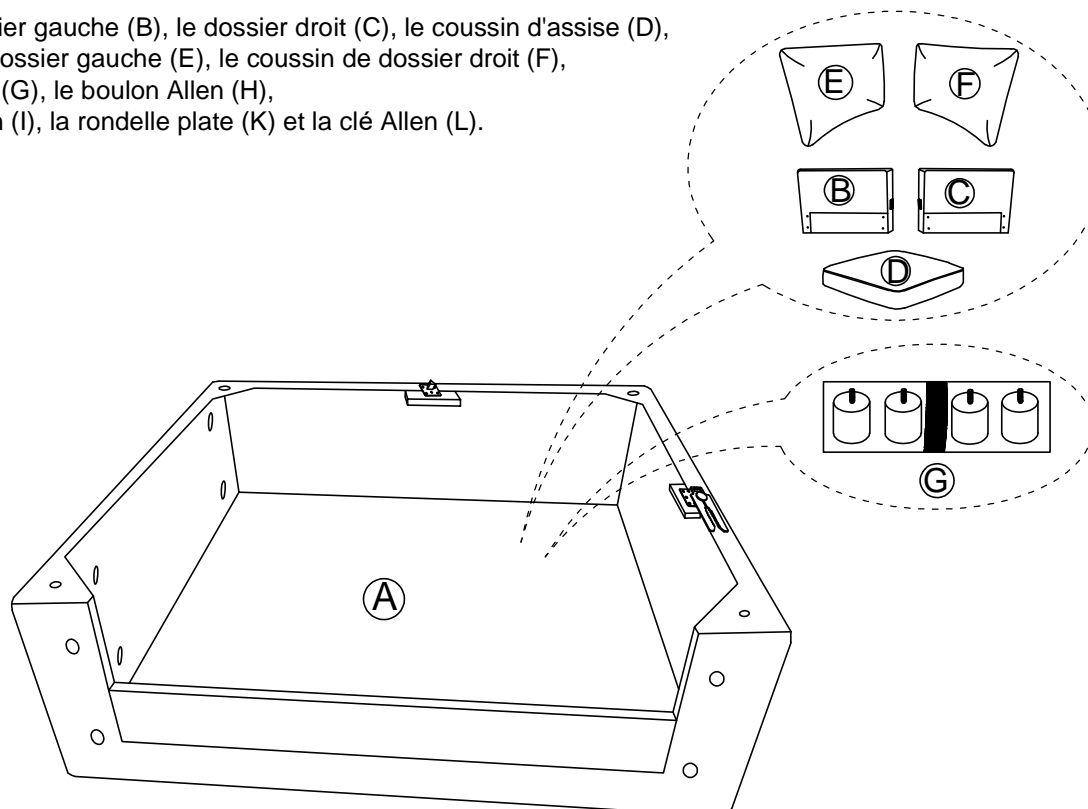

**STEP 2/ ÉTAPE 2:** Align Wooden Leg (G) onto the bottom of the Seat Frame(A), rotate to tighten it.  
Alignez le pied en bois (G) sur le bas du cadre du siège (A), tournez pour le serrer.

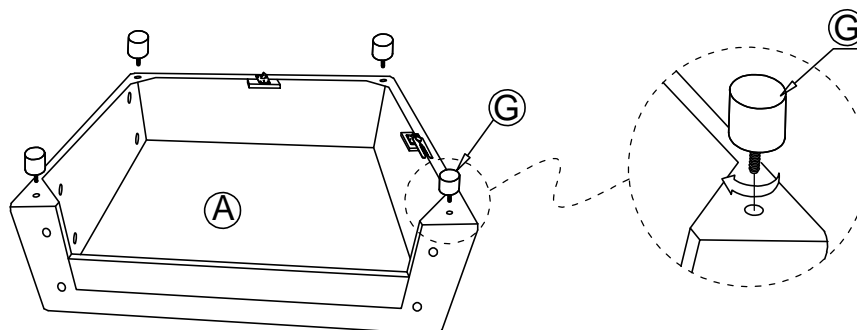

**STEP 3/ ÉTAPE 3:** Insert Left Back Rest(B) into Right Back Rest(C).  
Insérer le dossier gauche (B) dans le dossier droit (C).

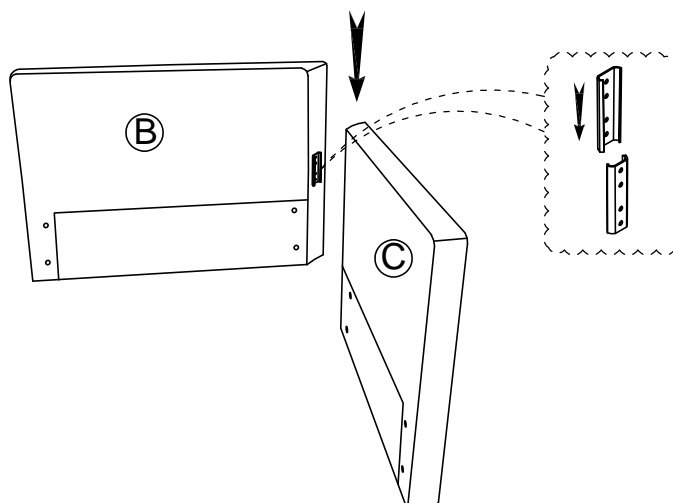

**STEP 4/ ÉTAPE 4:**

Place seat cushion on the seat frame.  
Match holes of Left Back Rest(B), Right Back Rest(C) and Seat Frame(A) correctly. Screw Allen Bolt(H) Lock Washer(I). Flat Washer(K) with Allen Key(L).

Placez le coussin d'assise sur le cadre du siège.  
Alignez correctement les trous du dossier gauche (B), du dossier droit (C) et du cadre du siège (A).  
Vissez la vis Allen (H), la rondelle frein (I) et la rondelle plate (K) à l'aide de la clé Allen (L).

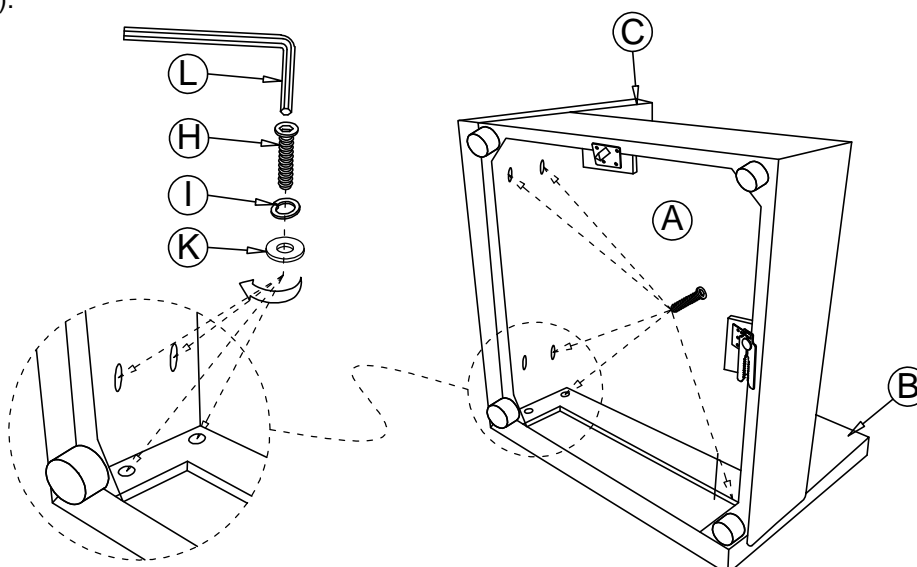

**STEP 5/ ÉTAPE 5:** Put Seat Cushion(D) on the Seat Frame(A).  
Placez le coussin de siège (D) sur le cadre de siège (A).

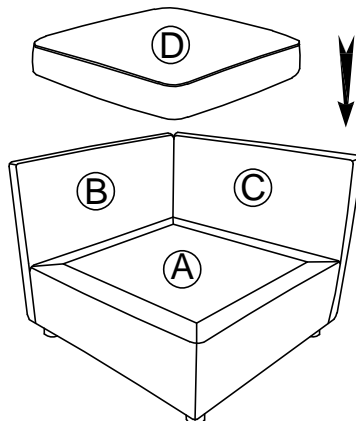

## STEP 6/ ÉTAPE 6:

Put Left Back Cushion(E) and Right Back Cushion(F) on Seat Cushion(D).  
Placez le coussin arrière gauche (E) et le coussin arrière droit (F) sur le coussin de siège (D).

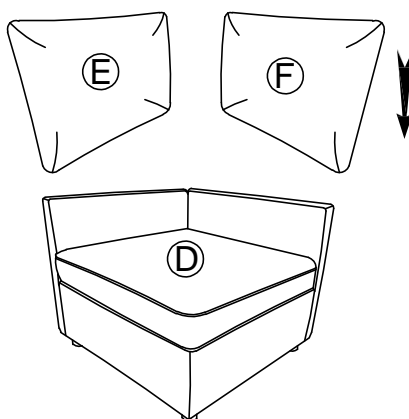

**STEP 7/ ÉTAPE 7**  
(Completed/ Complété):

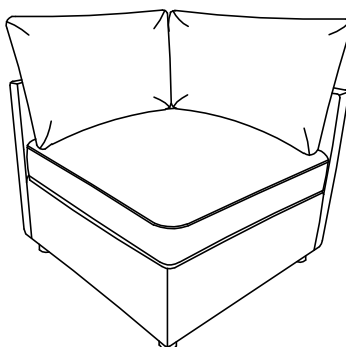



### CARE INSTRUCTIONS FOR FABRIC FURNITURE

To maintain the original appearance of your fabric furniture, please follow the simple care procedures below:

\* Avoid exposing furniture directly to sunlight or heating and air conditioning outlets. Exposure to sunlight or heating and air conditioning outlets will fade/damage fabric.

\* Wipe gently with a damp soft cloth to remove dust, dirt and any grime build up.

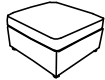
NO/ NON.	PARTS LIST/ LISTE DES PIÈCES	QTY/ QTÉ	DESCRIPTION
A		2	CR-Corner Seat/ Siège d'angle CR
B		2	AC-Armless Chair/ Chaise sans accoudoirs AC
C		1	4-Ottoman

### STEP 8/ ÉTAPE 8:

Sectional connection by placing (B) into piece (A) Continue sectional connection with piece (C) and (B) the same method.

Assemblage par sections en plaçant (B) dans la pièce (A) Continuer l'assemblage par sections avec la pièce (C) et (B) de la même manière.

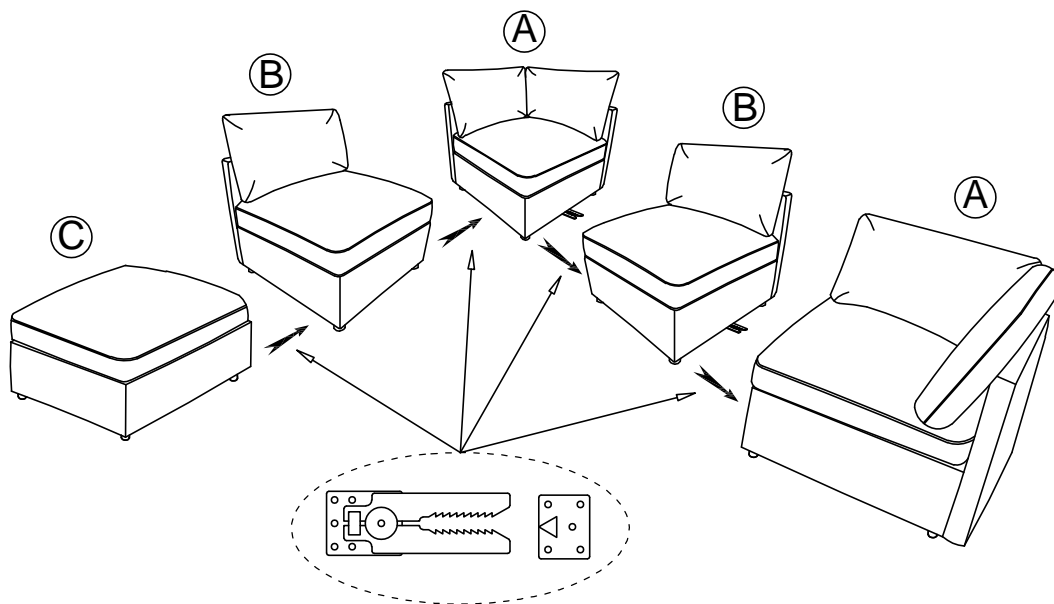

### STEP 9/ ÉTAPE 9

(Completed/ Complété):

